

# MC

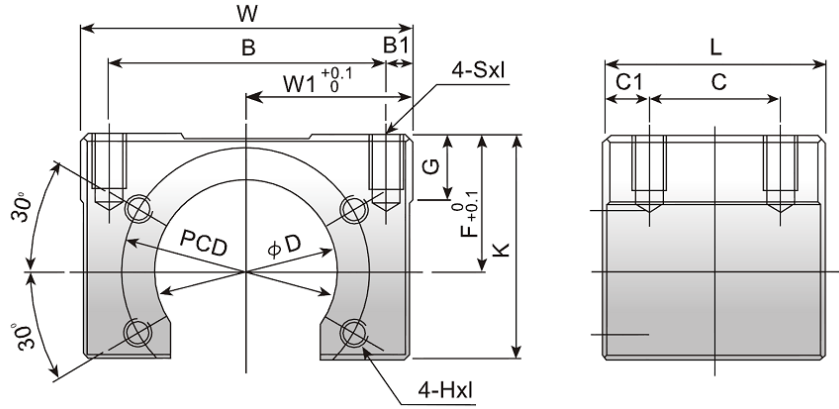

型号	D	W	W1	B	B1	L	C	C1	F	K	G	PCD	S×I	H×I
MC1004	26.4	48	24	40	4	32	16	10	20	32.5	9	36	M5X10	M4X7
MC1205	30.4	60	30	47	6.5	36	24	6	21	37	9	40	M6X12	M4X7
MC1404	31.4	60	30	50	5	36	20	10	21.5	37	9	40	M6X12	M4X8
MC1405	32.4	60	30	50	5	36	20	10	21.5	37	9	40	M6X12	M4X8
MC1408	34.4	60	30	50	5	36	20	10	21.5	37	9	45	M6X12	M5X7
MC1605	34.4	60	30	50	5	36	20	10	21.5	37	9	44	M6X12	M4X8
MC2005	46.4	86	43	70	8	50	30	10	31	54	16	50	M6X16	M4X8
MC2010	46.4	86	43	70	8	50	30	10	31	54	16	59	M10X20	M6X10
MC2020	39.4	86	43	70	8	40	24	8	28	51	16	59	M10X20	M6X10