

## 連座滾珠直線軸承-SC

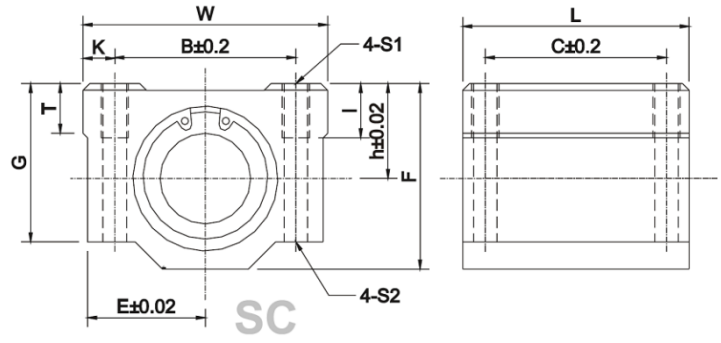

型號	軸徑	主要尺寸							安裝尺寸					重量 (KG)	
		h	E	W	L	F	G	T	B	C	K	S1	S2		I
SC 8	8	11	17	34	30	22	18	6	24	42	5	M4	3.4	8	0.1
SC10	10	13	20	40	35	26	21	8	28	46	6	M5	4.3	12	0.18
SC12	12	15	21	42	36	28	24	8	30.5	50	5.75	M5	4.3	12	0.20
SC13	13	15	22	44	39	30	24.5	8	33	50	5.5	M5	4.3	12	0.23
SC16	16	19	25	50	44	38.5	32.5	9	36	60	7	M5	4.3	12	0.39
SC20	20	21	27	54	50	41	35	11	40	70	7	M6	5.2	12	0.49
SC25	25	26	38	76	67	51.5	42	12	54	100	11	M8	7	18	1.165
SC30	30	30	39	78	72	59.5	49	15	58	110	10	M8	7	18	1.43
SC35	35	34	45	90	80	68	54	18	70	120	10	M8	7	18	2.13
SC40	40	40	51	102	90	78	62	20	80	140	11	M10	8.7	25	3.09
SC50	50	52	61	122	110	102	80	25	100	160	11	M10	8.7	25	6.53
SC60	60	58	66	132	122	114	94	30	108	180	12	M12	10.7	25	9.29