

# 引导式圆形法兰滚珠直线轴承加长型-LMFP-L

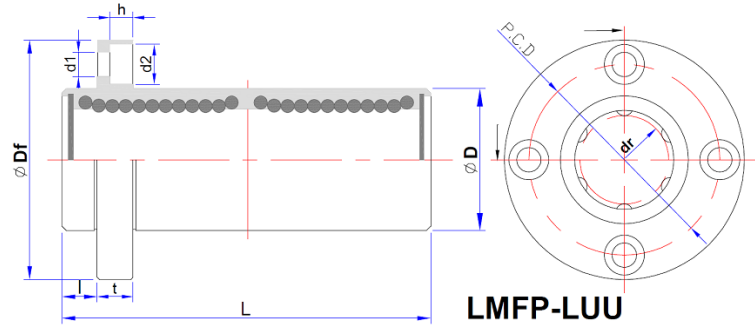

**LMFP-LUU**

主要尺寸														法兰垂 直度	径向 跳动 (max.)	基本额定负载									
型号	球列数	质量 g	内径		外径		长度		l	法兰			联接孔			动 C(kgf)	静 Co(kgf)								
			dr	公差	D	公差	L	公差		Df	t	P.C.D	d1	d2	h										
LMFP6L	4	31	6	0	12	0	35	0	5	28	5	20	3.5	6	3.1	0.015	0.015	33	54						
LMFP8L		51	8		15	-0.013	45			32	24	44						80							
LMFP10L		98	10		19	-0.010	55			40	29	60						112							
LMFP12L		110	12		21		0			57	42	32						83	160						
LMFP13L		130	13		23		-0.016			61	43	33						83	160						
LMFP16L		190	16		28		70			48	38	126						240							
LMFP20L	5	260	20	32	0	80	8	54	8	43	5.5	9	5.1	0.020	0.020	143	280								
LMFP25L	6	540	25	40	0	112	0	8	62	8	51	5.5	9	5.1	0.020	0.020	159	320							
LMFP30L		680	30	45	-0.012	123			74	60	254						560								
LMFP35L		1020	35	52	0	135			82	67	270						640								
LMFP40L		1570	40	60	0	151			96	78	350						820								
LMFP50L		3600	50	80	-0.015	-0.022			192	13	116						13	98	9	14	8.1	0.025	0.025	620	1622
LMFP60L		4500	60	90	0	0			209	18	134						18	112	11	17.5	10.8	0.025	0.025	770	2040