

# RSU

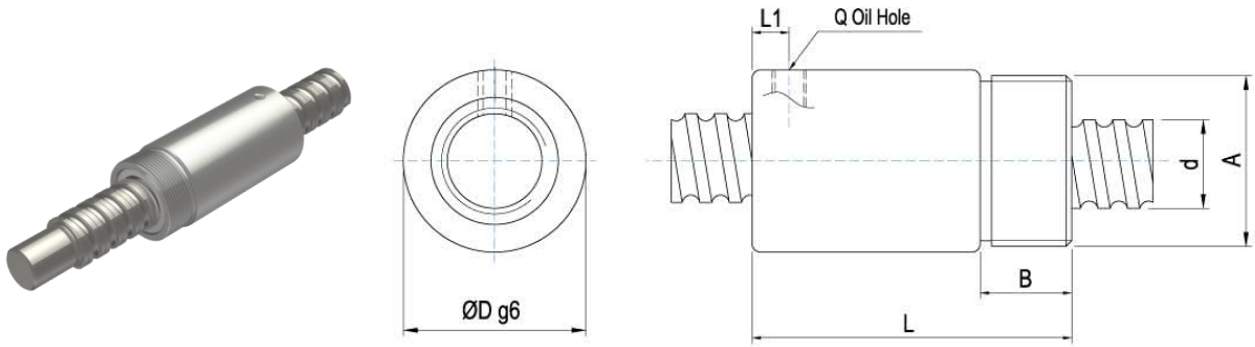

型号	规格											
	d	l	Da	D	A	B	L	Q	L1	n	Ca(kgf)	Coa(kgf)
▲1604-3	16	4	2.381	29	M22×1.5P	8	32	-	-	T3	435	920
1605-4	16	5	3.175	32	M30×1.5P	16	56	M6	6.5	T4	980	1650
2005-4	20	5	3.175	38	M35×1.5P	16.5	59.5	M6	7	T4	1100	2280
2505-4	25	5	3.175	42	M40×1.5P	17	60	M6	7	T4	1250	3070
2510-4	25	10	4.762	42	M40×1.5P	17	90	M6	10	T4	2070	4270
3205-4	32	5	3.175	52	M48×1.5P	19	60	M6	7	T4	1400	4080
3210-4	32	10	6.35	52	M48×1.5P	19	93	M6	12	T4	3340	7080
4005-4	40	5	3.175	58	M56×1.5P	19	59	M8	6	T4	1575	5290
4010-4	40	10	6.35	65	M60×2P	27	102	M8	12	T4	3850	9470
5010-4	50	10	6.35	78	M72×2P	29	104	M8	12	T4	4390	12400

▲无刮刷器