

開口連坐滾珠直線軸承-SME

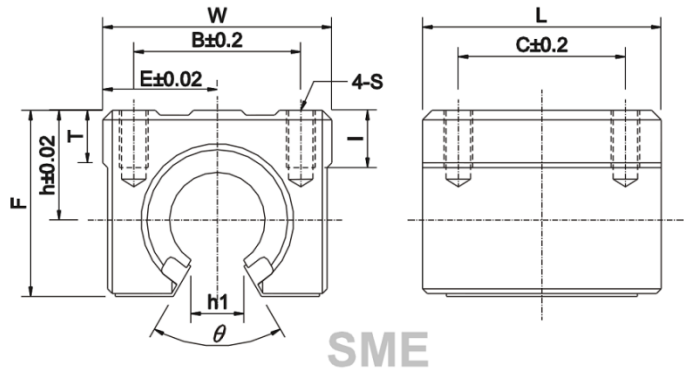

SME

型號	軸徑	主要尺寸								安裝尺寸				基本定額荷重		重量 (KG)
		h	E	W	L	F	T	h1	θ	B	C	S	l	動 C(kgf)	靜 C ₀ (kgf)	
SME10	10	15	18	36	32	24	7	6	80°	25	20	M5	10	38	56	0.065
SME12	12	17	20	40	39	27.6	8	8.5		28	26	M5	10	42	61	0.100
SME13	13	17	20	40	39	27.6	8	8.5		28	26	M5	10	52	80	0.100
SME16	16	20	22.5	45	45	33	9	10		32	30	M5	12	59	91	0.150
SME20	20	23	24	48	50	39	11	10	60°	35	35	M6	12	88	140	0.200
SME25	25	27	30	60	65	47	14	11.5	50°	40	40	M6	12	100	160	0.45
SME30	30	33	35	70	70	56	15	14		50	50	M8	18	160	280	0.63
SME35	35	37	40	80	80	63	18	16		55	55	M8	18	170	320	0.92
SME40	40	42	45	90	90	72	20	19		65	65	M10	20	220	410	1.33
SME50	50	53	60	120	110	92	25	23		94	80	M10	20	390	810	3.00