

Standard Runner Blocks R0442

All steel parts of the runner block are made of rust and acid resistant material similar to ISO 683-17 / EN 10088. The runner blocks are delivered mounted on arbors.

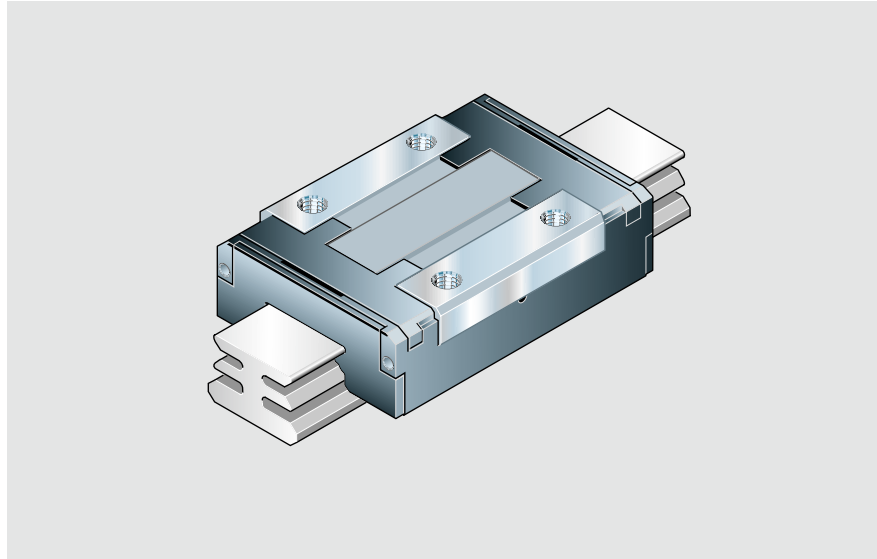

Part numbers for runner blocks

Standard seals: low-friction seals.
Part number: R0442 ... **01** (see table)
Special versions:

Runner blocks are also available:

- with N seals (excellent wiping action)
Sizes 15 and 20 have additional longitudinal seals for full sealing.
Part number: R0442 ... **00** (otherwise as per table)
- without basic lubrication for individual lubrication.
 - sizes 15 and 20 additionally with N seals and longitudinal seals
Part number: R0442 ... **40** (otherwise as per table)
 - with low-friction seals
Part number: R0442 ... **41** (otherwise as per table)

Size	Accuracy class	Part numbers for runner blocks	
		Clearance 9	Preload 1
7	P	-	R0442 712 01
	H	R0442 793 01	R0442 713 01
	N	R0442 794 01	-
9/M3	P	-	R0442 812 01
	H	R0442 893 01	R0442 813 01
	N	R0442 894 01	-
12	P	-	R0442 212 01
	H	R0442 293 01	R0442 213 01
	N	R0442 294 01	-
15	P	-	R0442 512 01
	H	R0442 593 01	R0442 513 01
	N	R0442 594 01	-
20	P	-	R0442 012 01
	H	R0442 093 01	R0442 013 01
	N	R0442 094 01	-

Take frictional drag of the respective seals into account.
See "Technical Data", section "Friction and seals".

Note on dynamic load capacities and moments (see table)

Determination of the dynamic load capacities and moments is based on a travel life of 100,000 m. Often only 50,000 m are actually stipulated.

For comparison:
Multiply values C , M_t and M_L from the table by 1.26.

Ordering example 1:

Runner block size 12, accuracy class P, preloaded, standard seals
Ordering data: **R0442 212 01**

Ordering example 2:

Runner block size 7, accuracy class H, clearance, N seals
Ordering data: **R0442 793 00**

Ordering example 3:

Runner block size 15, accuracy class H, preloaded, N seals and longitudinal seals, no basic lubrication
Ordering data: **R0442 513 40**

Ordering example 4:



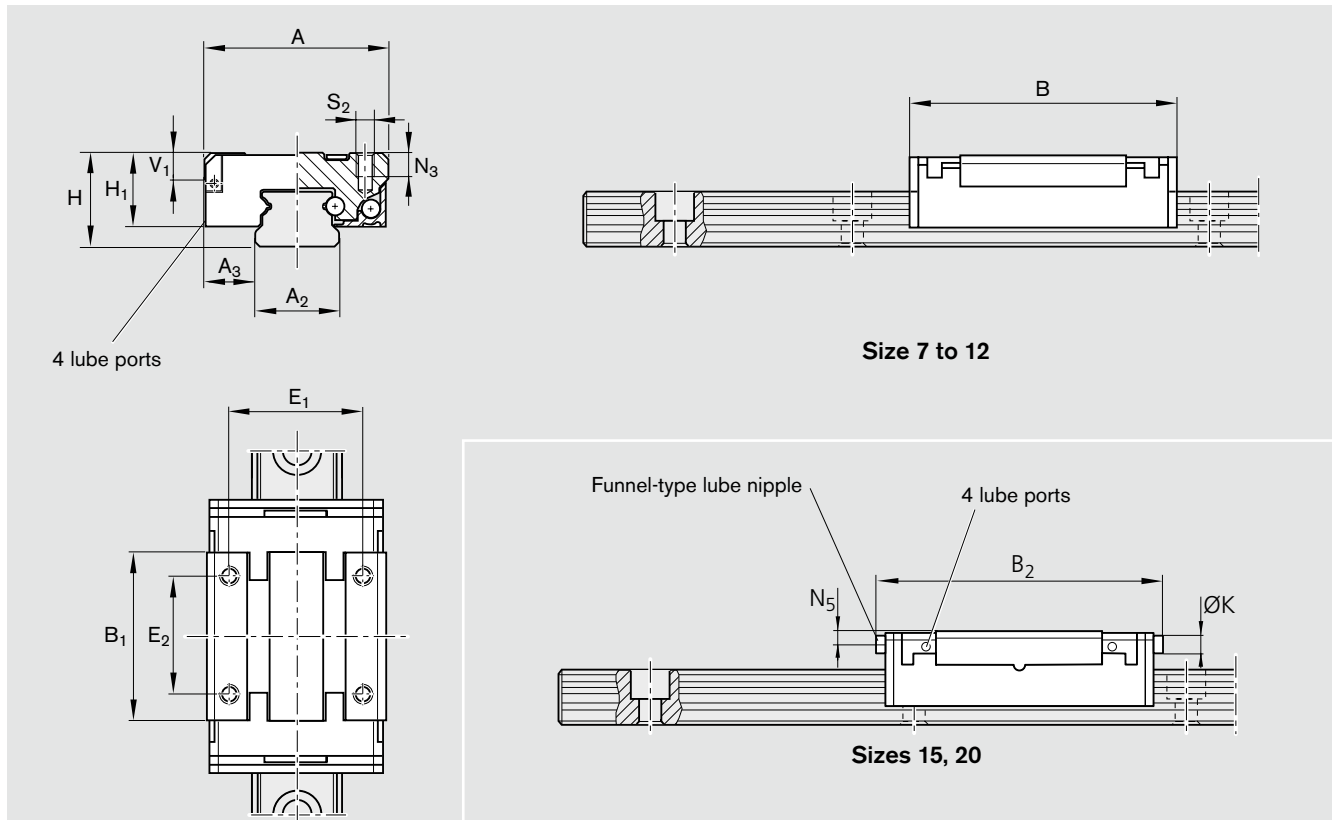



Runner block size 9/M3, accuracy class N, clearance, standard seals, no basic lubrication
Ordering data: **R0442 894 41**



Size	Dimensions (mm)															
	A	A ₂	A ₃	B	B ₁	B ₂	H	H ₁ ¹⁾	H ₁ ²⁾	V ₁	E ₁	E ₂	K	N ₃	N ₅	S ₂
7	17	7	5.0	24.0	14.9	-	8	6.5	-	2.0	12	8	-	2.5	-	M2
9/M3	20	9	5.5	31.0	20.7	-	10	8.0	-	2.8	15	10	-	3.0	-	M3
12	27	12	7.5	34.8	21.6	-	13	10.0	-	3.3	20	15	-	3.5	-	M3
15	32	15	8.5	43.0	27.2	46	16	12.0	12.65	4.7	25	20	4	4.0	2.1	M3
20	46	20	13.0	66.0	45.1	69	25	17.5	18.15	7.0	38	38	4	6.0	3.1	M4

1) Without longitudinal seal

2) With longitudinal seal

Size	Weight Runner block (g)	Load capacities (N)		Moments (Nm)			
		 C ¹⁾	 C ₀ ¹⁾	 M _t ²⁾	 M _{t0} ²⁾	 M _L ²⁾	 M _{Lo} ²⁾
7	9	860	1400	3.1	5.1	1.9	3.2
9/M3	16	1180	2100	5.4	9.6	3.6	6.4
12	33	2310	3470	13.7	20.6	7.9	11.8
15	47	4200	6260	31.2	46.3	18.3	27.0
20	177	7900	12230	81.4	126.0	51.7	80.0

1) Calculated values conforming to DIN 636, Part 2

2) Calculated values (based on C, C₀)